



Quality Products for Landscape & Agriculture

# TECHNICAL SPECIFICATIONS

## 12" RECTANGULAR VALVE BOX

### SPECIFICATIONS:

The LANDSCAPE PRODUCTS 12" Rectangular Valve Box and cover are injection molded of structural foam polyolefin material with a melt index between 10-12. Coloring and UV stabilizers are added, along with processing lubricants when needed. The 12" rectangular body shall be tapered and have a minimum wall thickness of 0.187". The body shall have a double wall at the top cover seat area with a minimum thickness of 0.200". The cover seat area shall have 18 structural support ribs on the underside of the seat, each with a minimum thickness of 0.200". The bottom of the body shall have a 0.500" flange. The 12" rectangular cover shall have an average thickness of 0.200". The valve box shall have a 3/8" 304 SS nut for the bolt-down as a standard feature.

Properties of unfoamed resin	ASTM Test Method	Polyethylene
Tensile Strength, Yield	ASTM D 638	3400 psi
Density	ASTM D 792	95 g/cc min
Durometer, Shore D	ASTM D 2240	55 min
Flexural Modulus	ASTM D 790	140,000 PSI min
Notched Izod Impact Strength @ 23 degrees C	ASTM D 256	-1.5 ft lb/in min
Heat Deflection Temperature @ 66 PSI	ASTM D 648	150° F

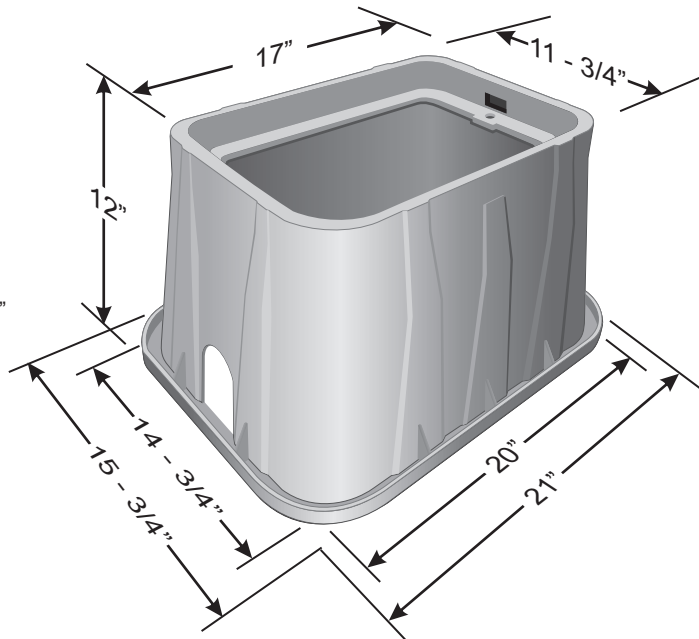
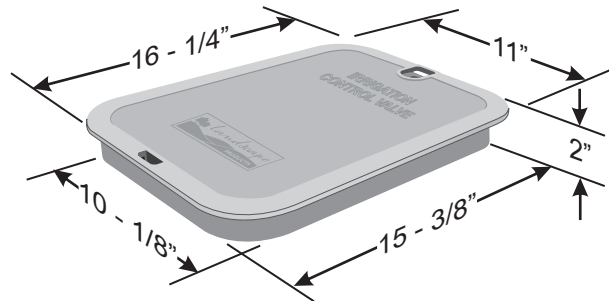

PIPE SLOT: 2-3/4" x 2-1/2"



All Landscape Products valve boxes are manufactured in California, USA.