



TECHNICAL SPECIFICATIONS

10" ROUND VALVE BOX

SPECIFICATIONS:

The LANDSCAPE PRODUCTS 10" Round Valve Box and cover are injection molded of structural foam polyolefin material with a melt index between 10-12. Coloring and UV stabilizers are added, along with processing lubricants when needed. The 10" round body shall be tapered and have a minimum wall thickness of 0.200". The cover seat area shall have 6 structural support ribs on the underside of the seat, each with a minimum thickness of 0.250". The bottom of the body shall have a 0.500" flange. The 10" round cover shall have an average thickness of 0.250".

Properties of unfoamed resin	ASTM Test Method	Polyolefin
Tensile Strength, Yield	ASTM D 638	3100-4400 psi
Density	ASTM D 792	.900-.956
Notched Izod Impact Strength	ASTM D 256	4-15 ft lb/in
Heat Deflection Temperature @ 66 PSI	ASTM D 648	165-212° F

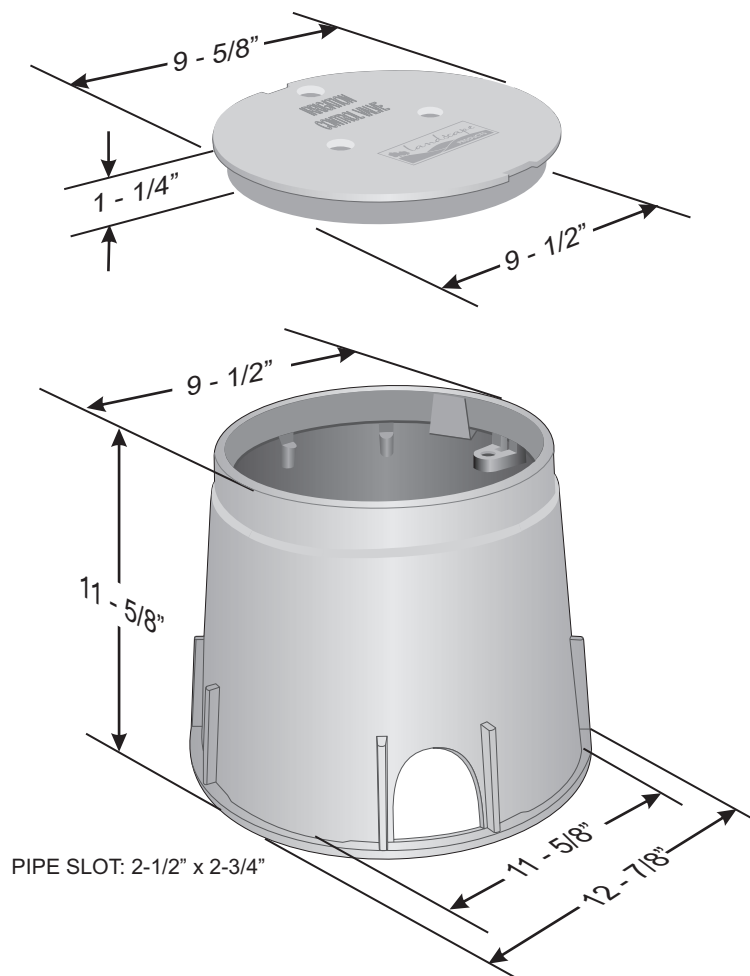

All Landscape Products valve boxes are manufactured in California, USA.